

TOC Measurement in the Chemical/ Petrochemical Industry

Introduction

Chemical and petrochemical plants consume large amounts of water for processing product. Large chemical companies like BASF, Bayer, Dow, and others are organised into business units. Each business unit is responsible for the production of a particular raw material (polypropylene, polyethylene, acids, caustics, etc.). These raw materials are consumed in the production of final products such as PTFE, Kynar, fertilisers, cleaning agents and specialty chemicals).

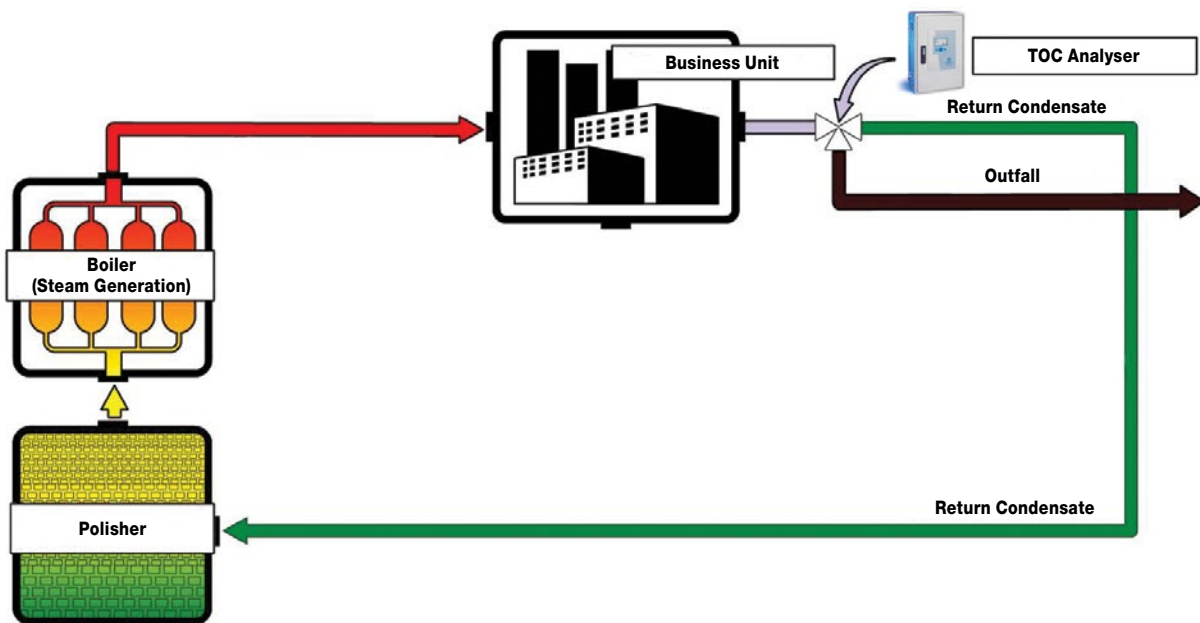

Figure 1. TOC Return Condensate Application

Return Condensate Application for TOC Analysis

Water is heated in the boiler to create steam that is used for power generation, and cracking hydrocarbons in preparation for further processing. Once the steam is used for heating in the production, the steam is condensed and the TOC levels are measured. A TOC measurement here, will determine whether the steam can be recycled back to the boiler or if it should be discharged (see Figure 1). High TOC measurements in the condensate are an indication of leaks in the heat exchangers, and this contamination can damage boilers.

If the steam condensate can be reused, the business unit receives a credit for the returned steam. In many plants the business unit receives a higher credit if the steam condensate is monitored for TOC.

APPLICATION: TOC MEASUREMENT

Once steam condensate has been sent to the outfall, it is considered consumed, and the business unit is charged for the complete cost of making up new water to replenish the steam condensate that was contaminated. The business units are individually responsible for their own productivity and efficiency based in part on steam consumption. A central steam plant feeds all of the business units at a particular site, and charges the business units according to their usage. Measuring TOC not only makes the use/reuse decision automatic, it provides a gauge for the amount of cleanup that will be necessary.

To be repolished, the steam must be cooled or condensed into water and it must be relatively clean; therefore this application requires low-level monitoring. We recommend a Hach® Biotector B3500c in the range of 0 - 10 mg/L, 0 - 25 mg/L, 0 - 50 mg/L or 0 - 100 mg/L, typically installed between the condenser and the return condensate pipe in a temperature-controlled analyser shelter or in the utilities building.

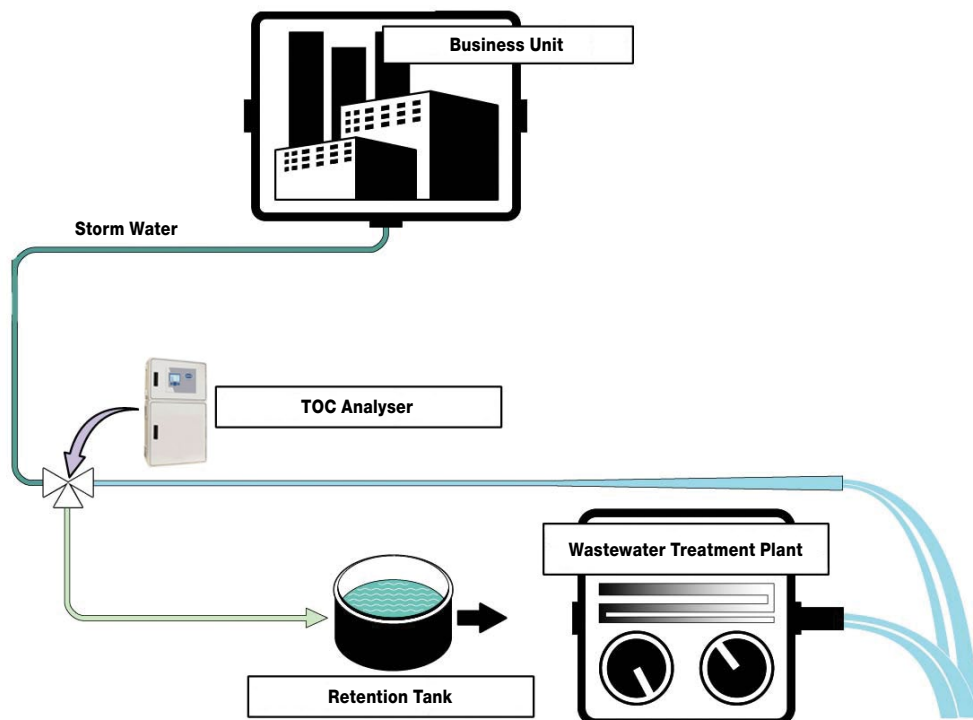

Figure 2. TOC Storm Water Application

Storm Water Application for TOC Analysis

Chemical and petrochemical plants are surrounded by storm water ditches. These ditches are designed to contain storm water run off during rain conditions or a major spill. Typically storm water run off is permitted for discharge into a body of water, untreated, however because of the nature of chemical and petrochemical processes the storm water may have a high content of organic contaminants. When the TOC measurement is higher than the permitted level, it is diverted into a retention (holding) tank to be slowly released into the wastewater treatment plant. When the TOC measurement is lower than the permitted value, it is discharged untreated.

For example, at a chemical plant, a Hach Biotector B7000 is being used to measure the Total Organic Carbon of the storm water run off. The customer chose the B7000 TOC analyser because the oxidation method allows it to handle high concentrations of hard-to-oxidise organic products in the sample and high salt content. In this application, no filters were installed because the patented oxidation method used by the B7000 can handle particles up to 2 mm in size. The B7000 is also available with a self-cleaning option that cleans the sample path in the instrument after every measurement. This self-cleaning technology allows for maximum up time with minimal service requirements (6-month service intervals). During a storm event a level switch (rain gauge) will actuate a pump to draw sample from the storm water ditch to the analyser (see Figure 2).

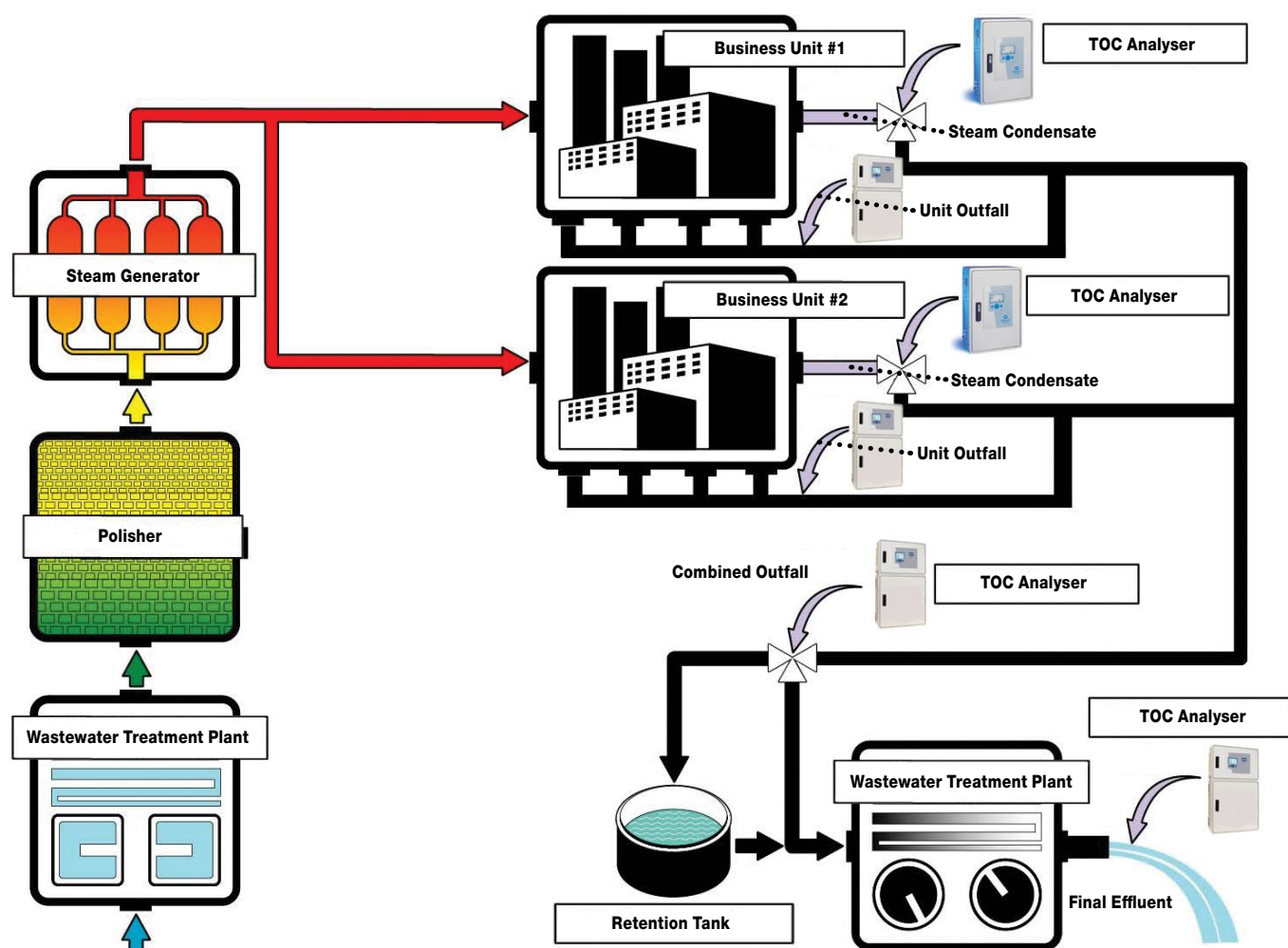

Figure 3. TOC Applications for Business Unit Outfall, Combined Outfall, and Final Effluent

Business Unit, Combined Outfall, and Final Effluent Applications for TOC Analysis

Because each business unit is judged on its own profitability, process water from each business unit and sometimes each individual stream is monitored for TOC. This assures that the business unit is charged fairly for the clean up. This measurement is typically performed by a Hach Biotector B7000 TOC analyser. The analyser is installed in the water line between the business unit and the waste stream (see Figure 3). Without a TOC measurement at each unit outfall, a combined outfall TOC measurement is taken and all the business units divide the cost of clean up evenly. Then the combined outfall is sent to the wastewater treatment plant for treatment. The Final Effluent is monitored for TOC and will have to meet the discharge permit limits before being discharged into a body of water.

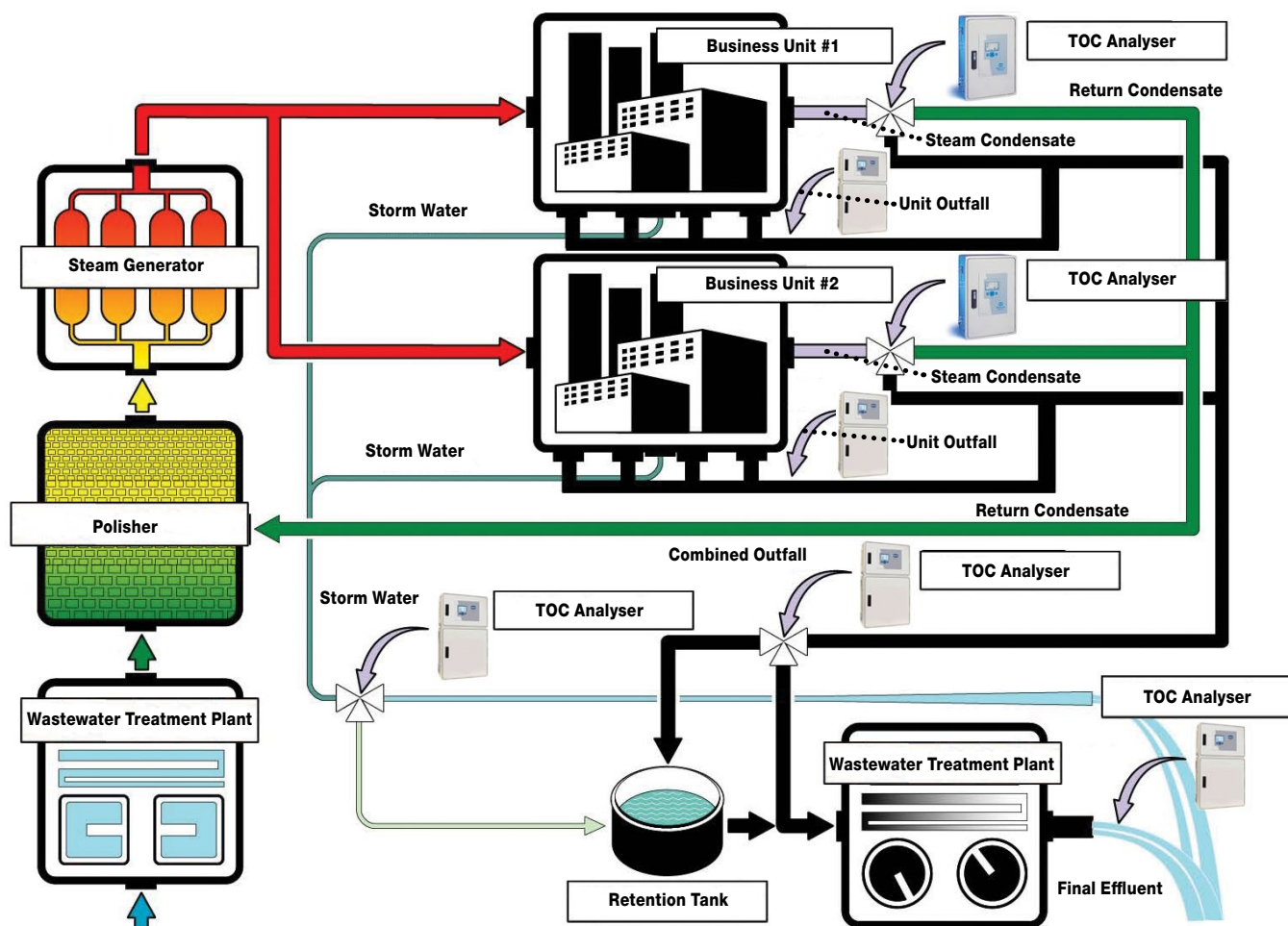

Figure 4. Summary of TOC Chemical and Petrochemical Applications

Summary of Applications

Petrochemical and chemical plants have many applications for TOC monitoring (see Figure 4). With the Hach Biotector family of analysers, these plants can improve process efficiency and avoid costly issues. Hach Biotector B7000 TOC analysers are designed for samples with high salt content (>300 ppm), oils, greases, difficult to oxidise compounds, or samples with high concentrations of solids. The B7000 is typically the analyser of choice for wastewater influent and effluent monitoring as well as business unit outfall applications. Hach Biotector B3500c condensate analysers are designed for clean industrial applications such as return condensate. Reach out to your local Hach representative for assistance in configuring the most reliable and accurate TOC analyser for your applications.